

DTS 1350

The DTS 1350 is based on the DTS 1300. It has a larger motor, but can still fit where there are severe space constraints. The DTS 1350 is a cantilever mount spindle that is intended primarily for tracing forms into grinding wheels. Although compact, the DTS 1350 is rigid and powerful enough to handle superabrasive applications. This model is intended to accommodate diamond rolls up to 4 inches (100 mm) in diameter and ½ inch (13 mm) wide.

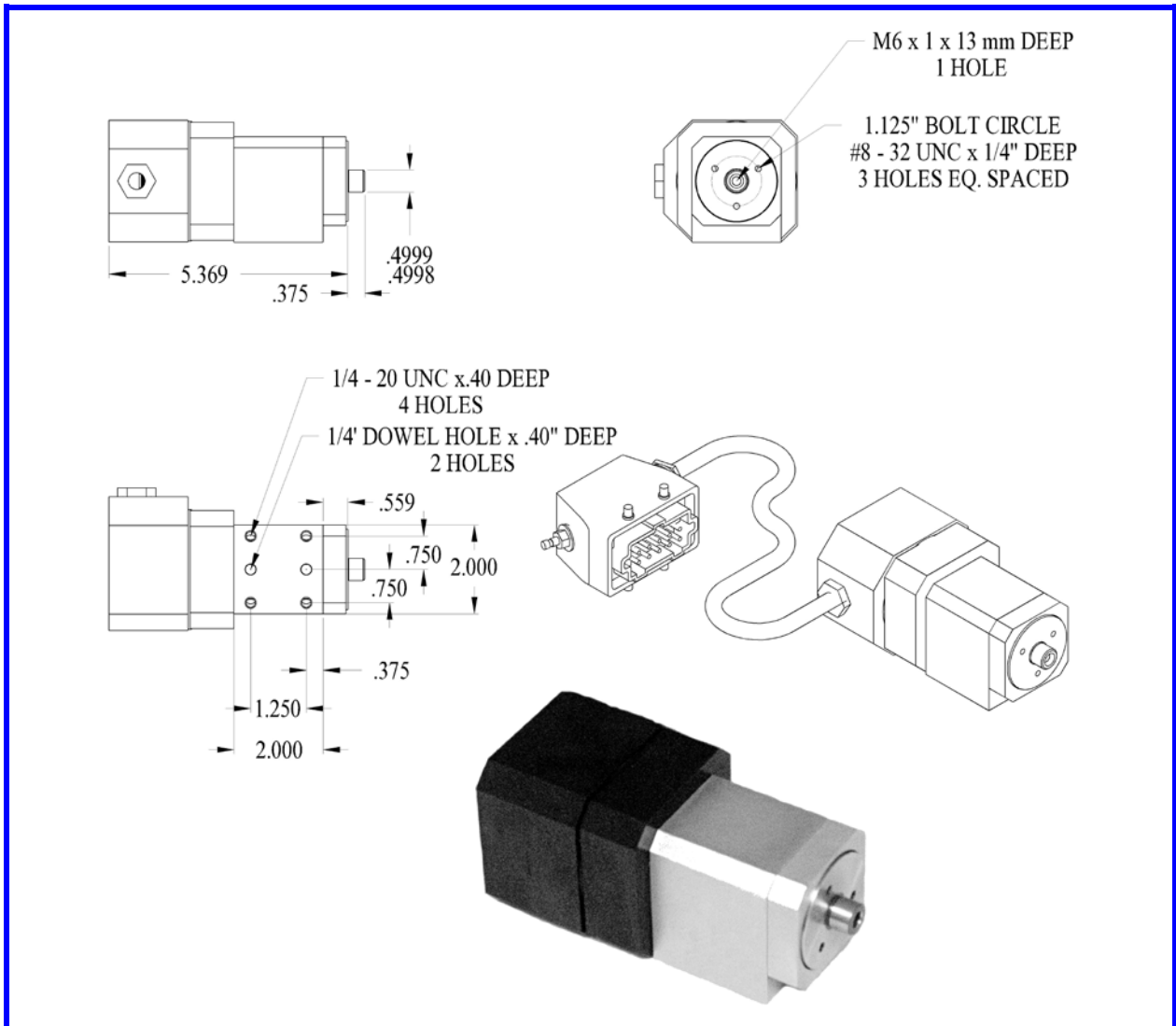

G II Solutions, Inc.
201 Bank Street
P.O. Box 428
Central, SC 29630

Phone: 864.639.6605
Fax: 864.639.4056
E-mail: info@giisolutions.com
Web Site: www.giisolutions.com